

Ordering Code:	<b>MH05CBT-X-Y-Z 03</b>
Stack Height :	63.0mm

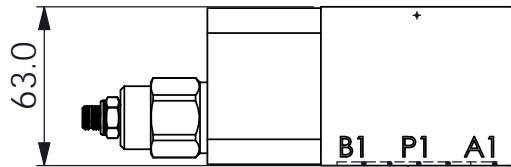

O-RING CODE NO.  
4KAA014AA001

UNIT:mm

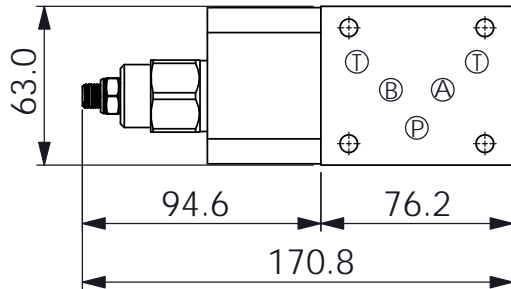
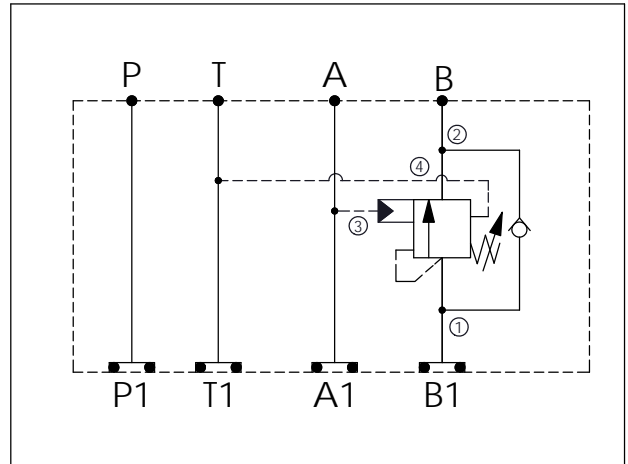
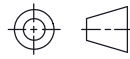

### TECHNICAL DATA

Aluminum Body Pressure Rating: 250 bar  
Ductile Iron Body Pressure Rating: 350 bar

Rated flow: 80 l/min

Cartridge Valve:

Refer to CW22A-X-Y-Z

\* Refer to Winner Cartridge Valve Catalog.

Aluminum	1.1 kg(WITHOUT VALVE)
	1.46 kg(INCLUDE VALVE)
Ductile Iron	3.1 kg(WITHOUT VALVE)
	3.46 kg(INCLUDE VALVE)

\* If you need the special specification.  
Please contact us.

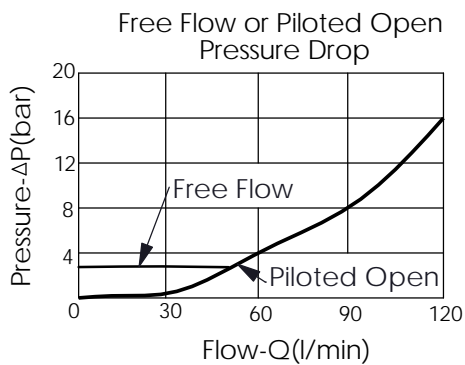

**X**

**SELECTION FOR G PORT**

**N**

WITHOUT PORT

**Y**

**SELECTION FOR B PORT CONTROL**

<b>22A4</b>	CAVITY ONLY(WITHOUT VALVE)
<b>CWAI</b>	CW22A4AIL (1:1 , 105bar)
<b>CWBF</b>	CW22A4BFL (2:1 , 175bar)
<b>CWCH</b>	CW22A4CHL (3:1 , 280bar)
<b>CWEF</b>	CW22A4EFL (5:1 , 175bar)

**Z**

**BODY MATERIAL**

**A**

HIGH-STRENGTH ALUMINUM

**S**

DUCTILE IRON