

Ordering Code: MH05CBW-X-Y-Z 21
Stack Height : 49.5mm

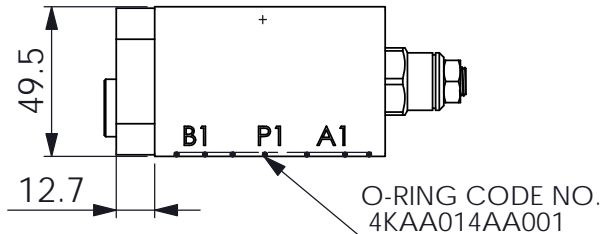

UNIT:mm

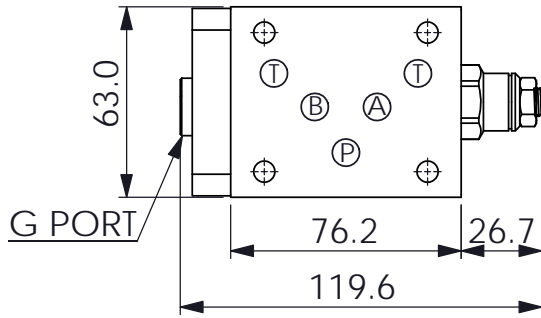
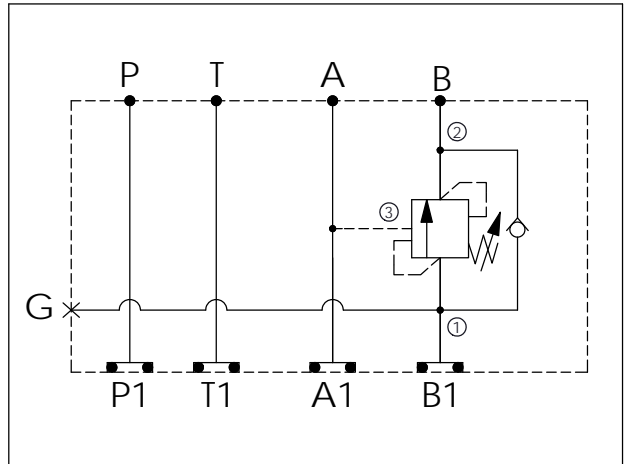
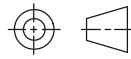

TECHNICAL DATA

Aluminum Body Pressure Rating: 250 bar
 Ductile Iron Body Pressure Rating: 350 bar

Rated flow: 60 l/min

Cartridge Valve:
 Refer to CB11A-X-Y-Z
 * Refer to Winner Cartridge Valve Catalog.

Aluminum	0.65 kg(WITHOUT VALVE) 0.85 kg(INCLUDE VALVE)

* If you need the special specification. Please contact us.

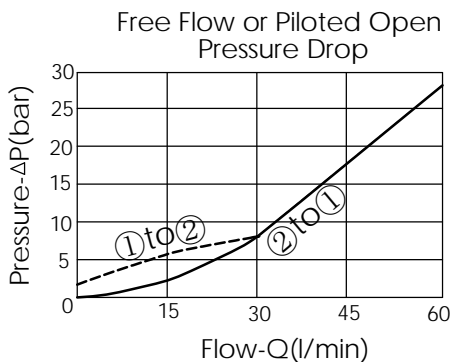

X SELECTION FOR G PORT

G02	G 1/4"(Metric)
N02	NPT 1/4"(U.S. Units)

Y SELECTION FOR B PORT CONTROL

11A3	CAVITY ONLY(WITHOUT VALVE)
CB3H	CB11A33HL (3:1 , 280bar)
CB4J	CB11A34JL (4.5:1 , 350bar)
CB0J	CB11A30JL (10:1 , 350bar)

Z BODY MATERIAL

A	HIGH-STRENGTH ALUMINUM
----------	------------------------