

Ordering Code:	MH05FBE-X-Y-Z03
Stack Height :	63.0mm

UNIT:mm

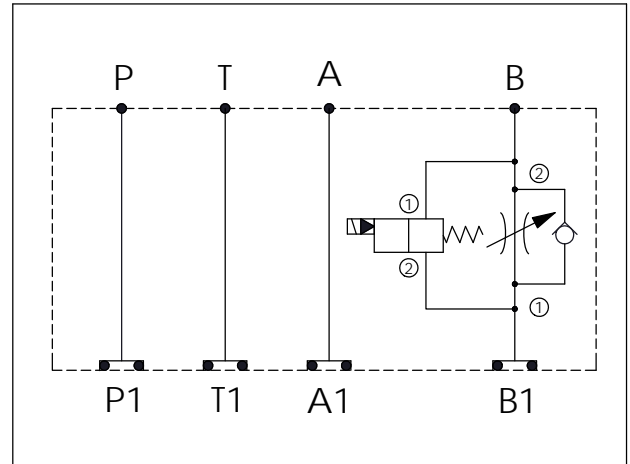

TECHNICAL DATA	
Aluminum Body Pressure Rating:	250 bar
Ductile Iron Body Pressure Rating:	350 bar
Rated flow:	80 l/min
Cartridge Valve:	Refer to NC5A-X-Y-Z EP12W-X-Y-Z
* Refer to Winner Cartridge Valves Catalog.	
Aluminum	1.05 kg(WITHOUT VALVES) 1.55 kg(INCLUDE VALVES ,WITHOUT COIL)

* If you need the special specification. Please contact us.

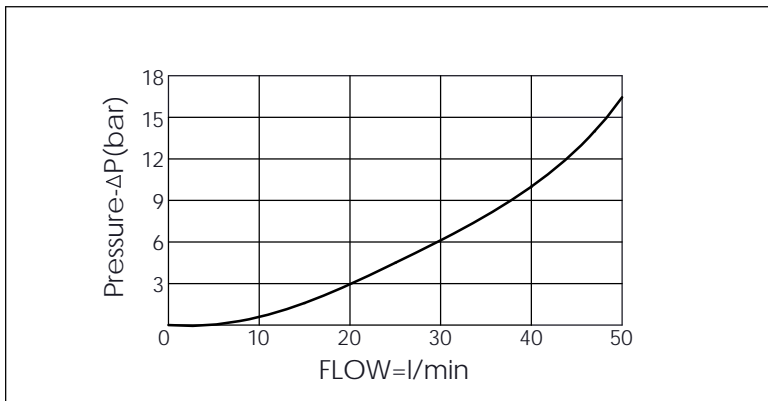

Y	SELECTION FOR SOLENOID VALVES (REFER TO EP12W-X-Y-Z)
12W2	CAVITY ONLY(WITHOUT VALVE)
EP01	EP12W2A01N05 , 150LPM,350bar (NORMALLY CLOSED,WITHOUT COIL)
EP02	EP12W2A02N05 , 150LPM,350bar (NORMALLY OPEN,WITHOUT COIL)
EP01M	EP12W2A01M05 , 150LPM,350bar(NORMALLY CLOSED WITH KNOB STYLE MANUAL OVERRIDE,WITHOUT COIL)
EP02P	EP12W2A02P05 , 150LPM,350bar(NORMALLY OPEN WITH PUSH STYLE MANUAL OVERRIDE,WITHOUT COIL)
COIL MUST BE ORDERED SEPARATELY (REFER TO EC-04W-X-Y-Z)	

X	SELECTION FOR FLOW CONTROL
5A2	CAVITY ONLY(WITHOUT VALVE)
NCBC	NC5A21BCL (2.0bar)

Z	BODY MATERIAL
A	HIGH-STRENGTH ALUMINUM