

Ordering Code: MH03FDO-X-Y-Z01	
Stack Height : 44.5mm	

O-RING CODE NO.
4KAA012AA001

UNIT:mm ⊕ ⚡

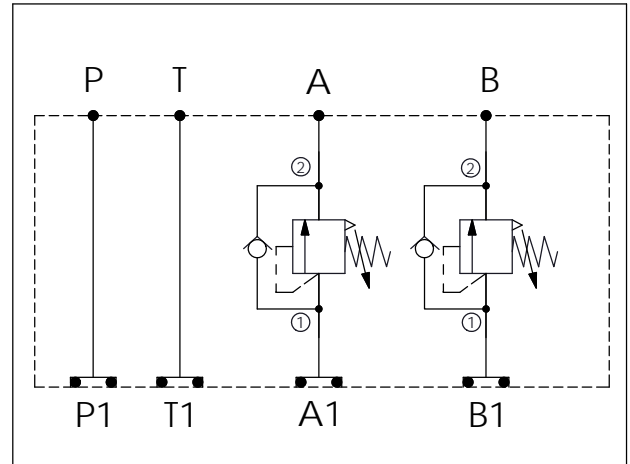

TECHNICAL DATA	
Aluminum Body Pressure Rating:	250 bar
Ductile Iron Body Pressure Rating:	350 bar
Rated flow:	40 l/min
Cartridge Valve: Refer to SC13A-X-Y-Z	
* Refer to Winner Cartridge Valves Catalog.	
Aluminum	0.4 kg(WITHOUT VALVES) 0.85 kg(INCLUDE VALVES)
Ductile Iron	1.15 kg(WITHOUT VALVES) 1.45 kg(INCLUDE VALVES)
* If you need the special specification. Please contact us.	

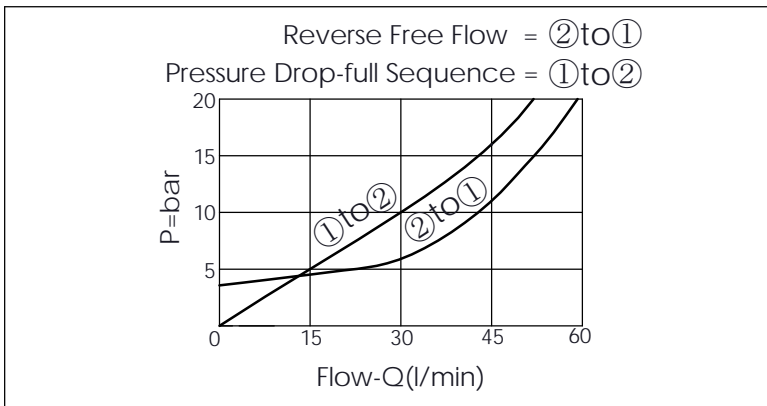

X	SELECTION FOR A PORT CONTROL
13A2	CAVITY ONLY(WITHOUT VALVE)
SC0A	SC13A20AL (60LPM,35-210bar)

Y	SELECTION FOR B PORT CONTROL
13A2	CAVITY ONLY(WITHOUT VALVE)
SC0A	SC13A20AL (60LPM,35-210bar)

Z	BODY MATERIAL
A	HIGH-STRENGTH ALUMINUM
S	DUCTILE IRON