

Ordering Code: **MH05FTW-X-Y-Z01**
 Stack Height : 49.5mm

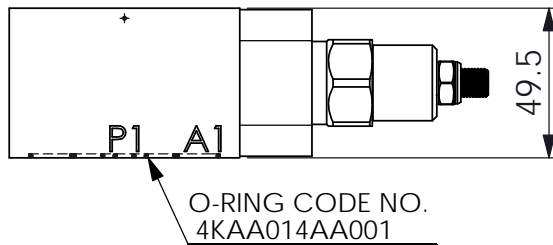

UNIT:mm

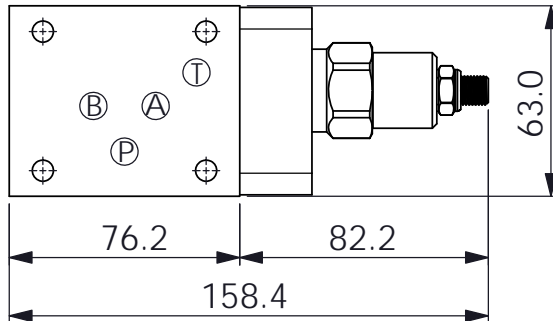
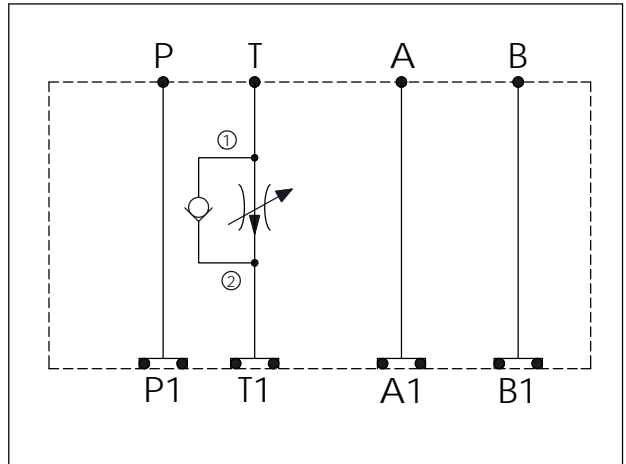
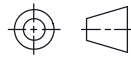

TECHNICAL DATA

Aluminum Body Pressure Rating: 250 bar
 Ductile Iron Body Pressure Rating: 350 bar
 Rated flow: 45 l/min (Pressure Compensated)

Cartridge Valve:
 Refer to FR5A-X-Y-Z
 * Refer to Winner Cartridge Valves Catalog.

| | |
|----------|--|
| Aluminum | 0.71 kg(WITHOUT VALVE) 0.98 kg(INCLUDE VALVE) |
| | |

* If you need the special specification. Please contact us.

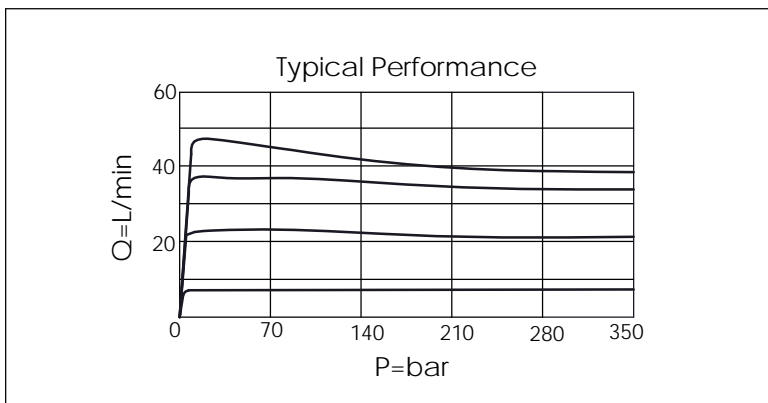

| X | SELECTION FOR T PORT CONTROL | |
|------|------------------------------|--|
| 5A2 | CAVITY ONLY(WITHOUT VALVE) | |
| FR0A | FR5A20AL (45 LPM , 350bar) | |
| | | |
| | | |

| Y | SELECTION FOR G PORT | |
|---|----------------------|--|
| N | WITHOUT PORT | |
| | | |
| | | |
| | | |
| | | |

| Z | BODY MATERIAL | |
|---|------------------------|--|
| A | HIGH-STRENGTH ALUMINUM | |
| | | |
| | | |
| | | |
| | | |