

Ordering Code: **MH03PPW-X-Y-Z 01**

Stack Height : 44.5mm

UNIT:mm

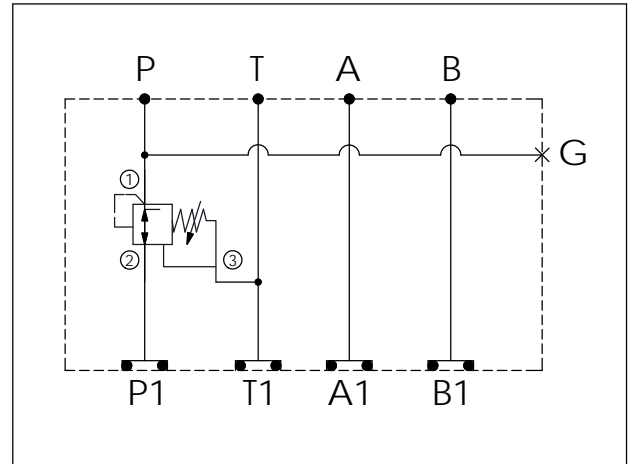

TECHNICAL DATA

Aluminum Body Pressure Rating: 250 bar
 Ductile Iron Body Pressure Rating: 350 bar

Rated flow: 40 l/min

Cartridge Valve:
 Refer to PD11A-X-Y-Z
 * Refer to Winner Cartridge Valve Catalog.

Aluminum	0.32 kg(WITHOUT VALVE) 0.5 kg(INCLUDE VALVE)
Ductile Iron	0.9 kg(WITHOUT VALVE) 1.08 kg(INCLUDE VALVE)

* If you need the special specification. Please contact us.

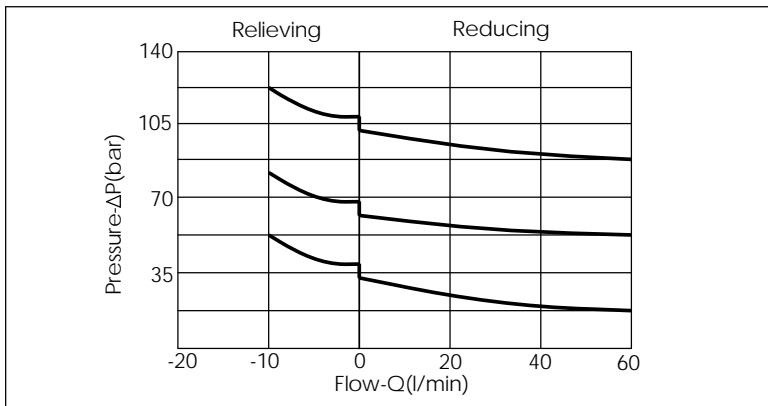

X	SELECTION FOR P PORT CONTROL
11A3	CAVITY ONLY(WITHOUT VALVE)
PD0A	PD11A30AL(40LPM,35-210bar) (Direct Acting)
PD0B	PD11A30BL(40LPM,3.5-105bar) (Direct Acting)
PD0D	PD11A30DL(40LPM,1.7-55bar) (Direct Acting)
PD0E	PD11A30EL(40LPM,1.7-28bar) (Direct Acting)

Y	SELECTION FOR G PORT
G02	G 1/4"(Metric)
N02	NPT 1/4"(U.S. Units)

Z	BODY MATERIAL
A	HIGH-STRENGTH ALUMINUM
S	DUCTILE IRON