

Ordering Code: **MH05RBA-X-Y-Z 01**

Stack Height : 49.5mm

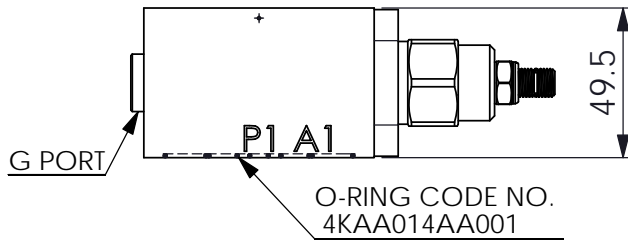

UNIT:mm

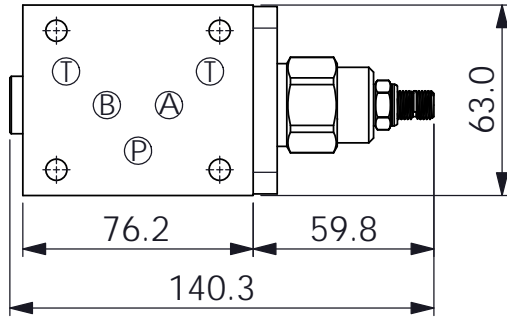
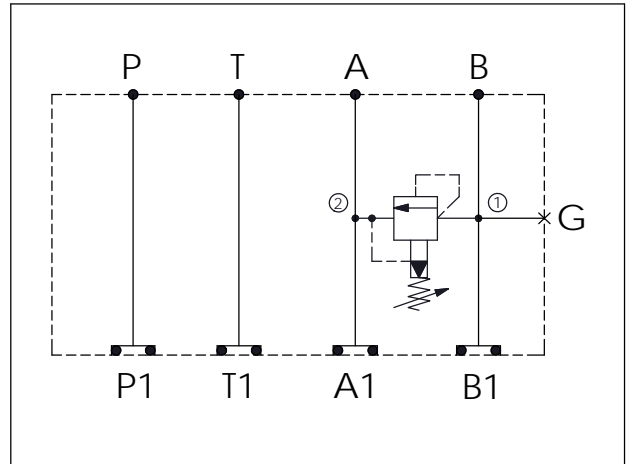
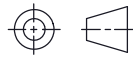

TECHNICAL DATA

Aluminum Body Pressure Rating: 250 bar

Ductile Iron Body Pressure Rating: 350 bar

Rated flow: 80 l/min

Cartridge Valve:
Refer to RP3A-X-Y-Z
* Refer to Winner Cartridge Valves Catalog.

Aluminum	0.56 kg(WITHOUT VALVE)
	0.81 kg(INCLUDE VALVE)

* If you need the special specification. Please contact us.

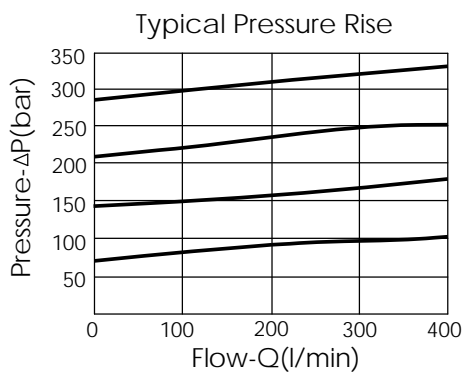

X SELECTION FOR G PORT

G02	G 1/4"(Metric)	
N02	NPT 1/4"(U.S. Units)	

Y SELECTION FOR B PORT CONTROL

3A2	CAVITY ONLY(WITHOUT VALVE)	
RP0A	RP3A20AL (200 LPM , 7-210bar)	

Z BODY MATERIAL

A	HIGH-STRENGTH ALUMINUM	