

ISO 05 SANDWICH MANIFOLD

Ordering Code: **MH05RBH-X-Y-Z01**

Stack Height : 49.5mm

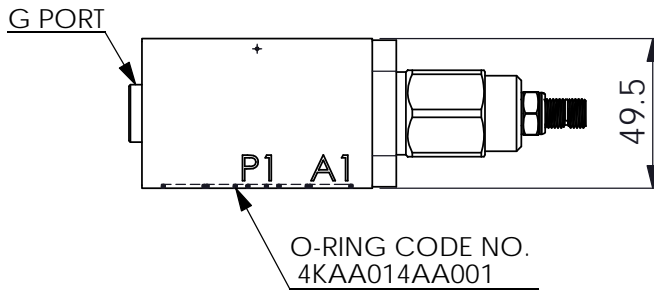
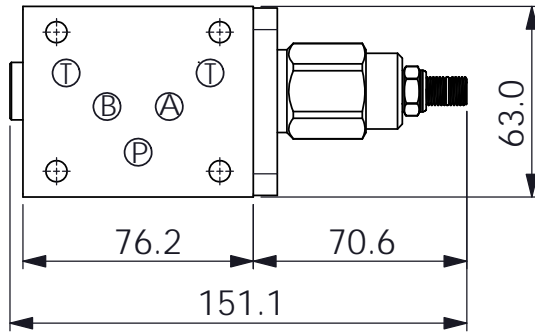

UNIT:mm

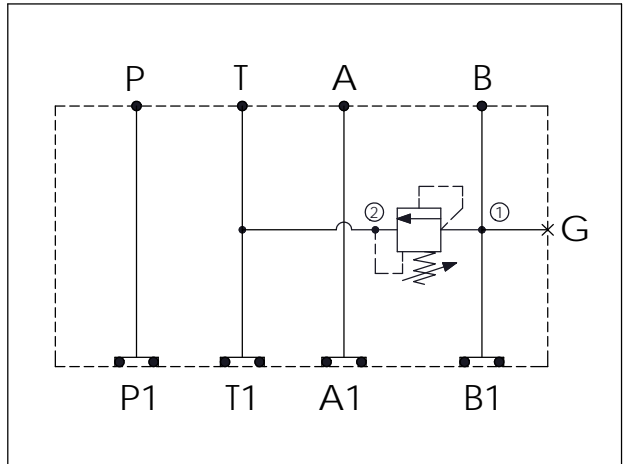
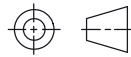

TECHNICAL DATA

Aluminum Body Pressure Rating: 250 bar

Ductile Iron Body Pressure Rating: 350 bar

Rated flow: 80 l/min

Cartridge Valve:
Refer to RD3A-X-Y-Z
* Refer to Winner Cartridge Valves Catalog.

Aluminum	0.56 kg(WITHOUT VALVE)
	0.86 kg(INCLUDE VALVE)

* If you need the special specification. Please contact us.

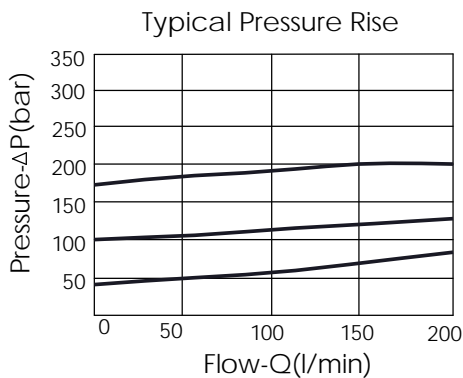

X	SELECTION FOR G PORT	
G02	G 1/4"(Metric)	
N02	NPT 1/4"(U.S. Units)	

Y	SELECTION FOR B PORT CONTROL	
3A2	CAVITY ONLY(WITHOUT VALVE)	
RD5A	RD3A25AL (200 LPM , 35-210bar)	

Z	BODY MATERIAL	
A	HIGH-STRENGTH ALUMINUM	