

ISO 05 SANDWICH MANIFOLD

Ordering Code: **MH05RDT-X-Y-Z01**

Stack Height : 49.5mm

UNIT:mm

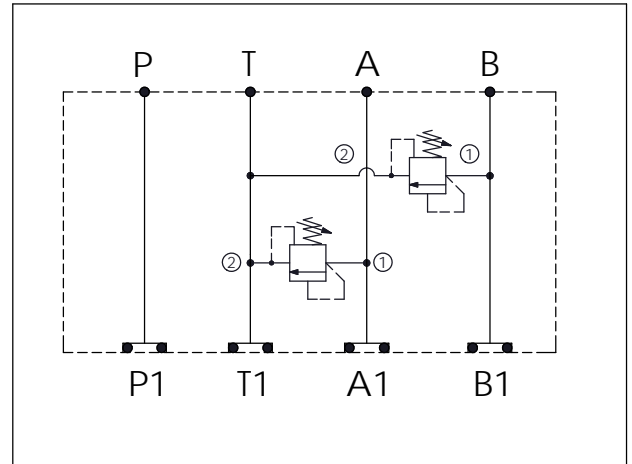

TECHNICAL DATA

Aluminum Body Pressure Rating: 250 bar

Ductile Iron Body Pressure Rating: 350 bar

Rated flow: 80 l/min

Cartridge Valve:
Refer to RD3A-X-Y-Z
* Refer to Winner Cartridge Valves Catalog.

Aluminum	0.85 kg(WITHOUT VALVES) 1.45 kg(INCLUDE VALVES)
Ductile Iron	2.45 kg(WITHOUT VALVES) 3.05 kg(INCLUDE VALVES)

* If you need the special specification. Please contact us.

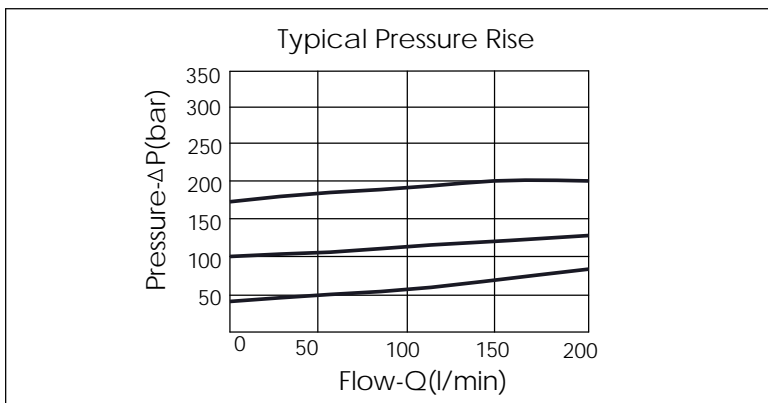

X	SELECTION FOR A PORT CONTROL	
3A2	CAVITY ONLY(WITHOUT VALVE)	
RD5A	RD3A25AL (200LPM , 35-210bar)	

Y	SELECTION FOR B PORT CONTROL	
3A2	CAVITY ONLY(WITHOUT VALVE)	
RD5A	RD3A25AL (200LPM , 35-210bar)	

Z	BODY MATERIAL	
A	HIGH-STRENGTH ALUMINUM	
S	DUCTILE IRON	