

ISO 05 SANDWICH MANIFOLD

Ordering Code:	MH05RTH-X-Y-Z01
Stack Height :	49.5mm

O-RING CODE NO.
4KAA014AA001

UNIT:mm

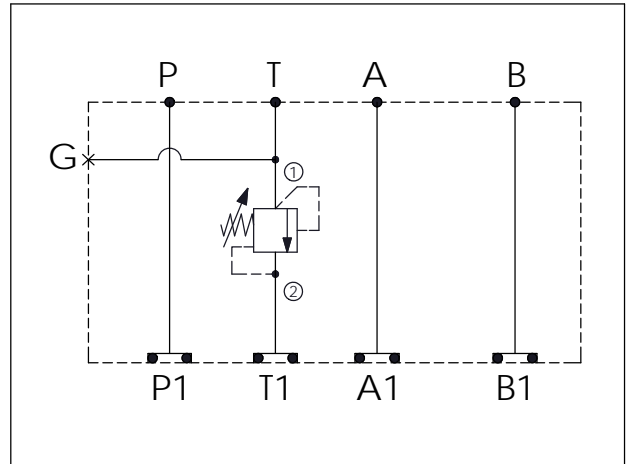

TECHNICAL DATA	
Aluminum Body Pressure Rating:	250 bar
Ductile Iron Body Pressure Rating:	350 bar
Rated flow:	80 l/min
Cartridge Valve:	Refer to RD3A-X-Y-Z
	* Refer to Winner Cartridge Valves Catalog.
Aluminum	0.74 kg(WITHOUT VALVE) 1.04 kg(INCLUDE VALVE)
* If you need the special specification. Please contact us.	

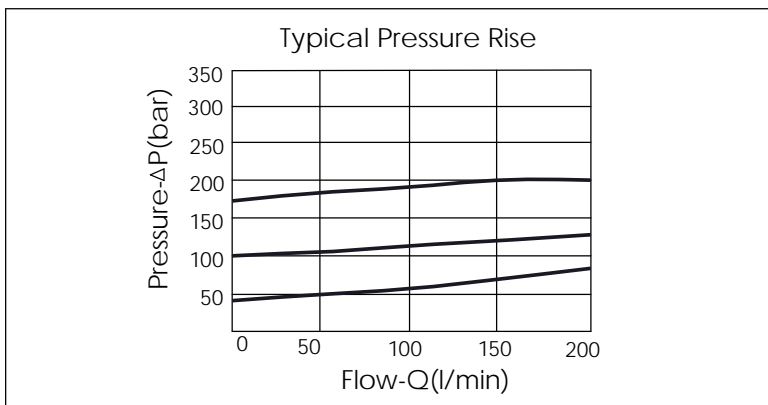

X	SELECTION FOR T PORT CONTROL
3A2	CAVITY ONLY(WITHOUT VALVE)
RD5A	RD3A25AL (200 LPM , 35-210bar)

Y	SELECTION FOR G PORT
G02	G 1/4"(Metric)
N02	NPT 1/4"(U.S. Units)

Z	BODY MATERIAL
A	HIGH-STRENGTH ALUMINUM